

# FLAMEPROOF EQUIPMENT DESIGN AND CERTIFICATION

---

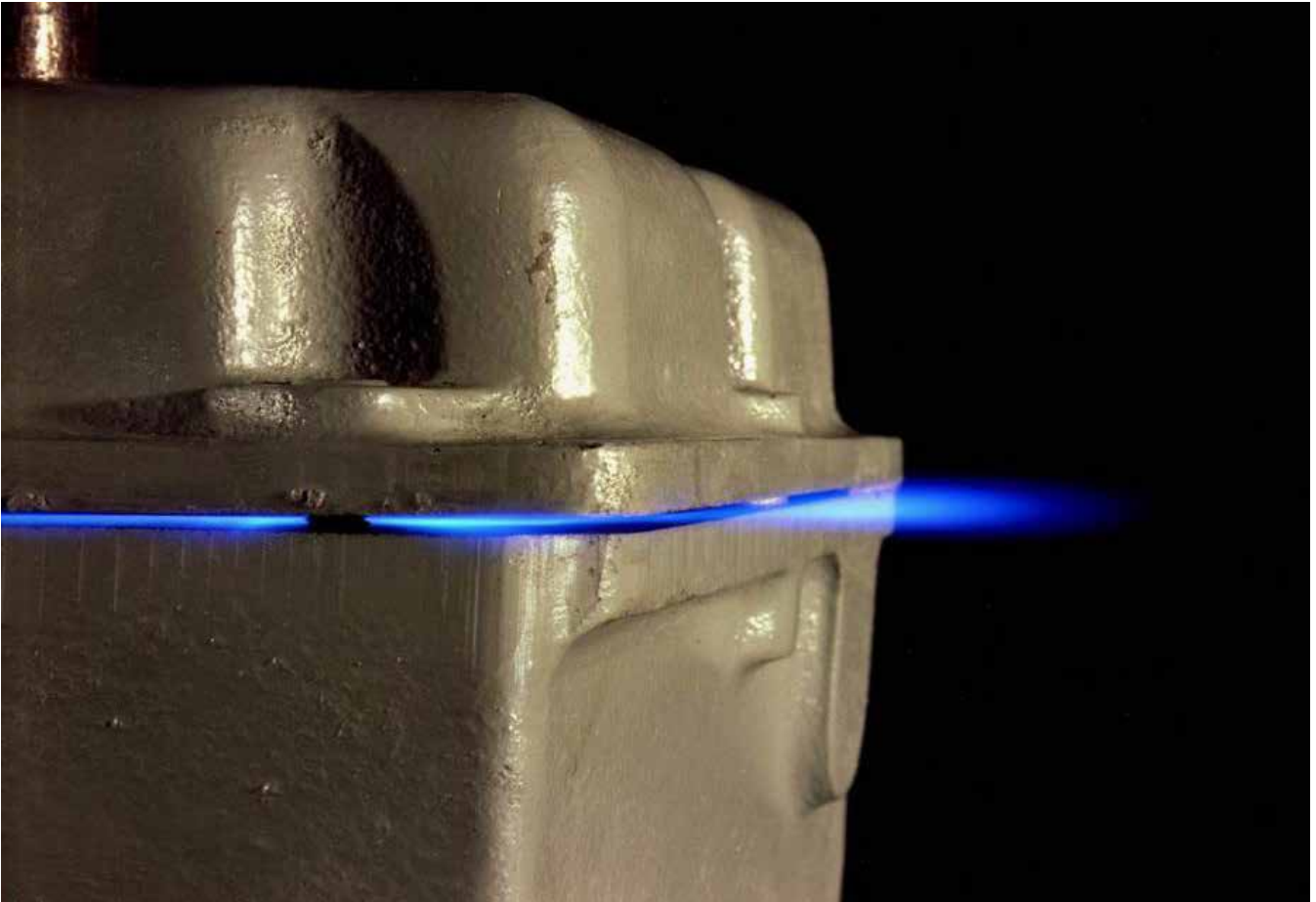

The purpose of this document is to assist engineers and manufacturers design flameproof equipment that satisfies the requirements of IEC 60079-0 and IEC 60079-1 and to help them provide meaningful documentation to smooth the path to certification.

If you are new to the mysteries of Ex Equipment and the various types of protection and certification schemes, we recommend that you start by familiarizing yourself with our “Introduction to Explosion Protection and Certification” document that can be downloaded from the link at the bottom of our web page [www.sgs.co.uk/sgsbaseefa](http://www.sgs.co.uk/sgsbaseefa)

# SGS BASEEFA

SGS Baseefa, and its antecedents, has over 90 years' experience in the application of standards to flameproof equipment and in assisting manufacturers gain certification for compliant products. We were involved from the start, during the 1920s, when the first versions of the flameproof standard (then known as FLP) were under development, as BS 229. We now represent UK manufacturers, purchasers and certifiers at today's international standards meetings, writing the latest editions of the IEC 60079 series of standards, with the introduction of three levels of flameproof protection Ex da, Ex db and Ex dc.

Although the "how" may be more complicated, the "what" of flameproof protection remains simple:

1. The flameproof enclosure may contain items that arc, spark or have hot surfaces, which will always present an ignition risk when a gas or vapour/air mixture gets inside
2. The enclosure must be sufficiently strong to contain the explosion, when it occurs – typically resisting pressures between 6 and 10 bar without bursting (although some equipment may see significantly higher pressures and be designed with greater strength)
3. The products of combustion (hot gases) must vent from the enclosure in such a way that they will not ignite an external explosive atmosphere
4. The temperature on the external surface of the enclosure must not be high enough to ignite an external gas or vapour/air mixture through "hot surface" ignition

It is reasonably easy to understand that rapidly burning a gas or vapour in air will result in hot gases. The actual temperature will depend on the particular mixture of gas or vapour with air. The concepts of richness and leanness apply equally to explosions as to the combustion of petrol in a car engine, with the maximum energy output relating to the "most explosive" mixture. As the exploding gases are confined in a fixed volume, we can easily predict, for simple situations, the peak pressure.

The applicable equation is the Universal Gas Law:

$$P \times V = \frac{\text{Constant}}{T}$$

If V is constant, the pressure is directly proportional to absolute temperature. For most gases this gives a peak pressure between 5 bar and 8 bar, in a simple enclosure. Unfortunately, not many enclosures are simple. They may be large, of unequal dimension and almost certainly have internal contents that determine how the explosion develops. For this reason, it is not usually possible to calculate pressures, but they are always determined by an actual explosion test. For complex constructions, such as electric motors, the pressures can rise rapidly and pressures in excess of 30 bar have been routinely observed. The subject of pressure piling and detonation is discussed later in this document.

**THE GAP**

Immediately after the peak explosion pressure, we have the hottest gases at the highest pressure, trying to escape from the enclosure. For the flameproof form of protection, it is accepted that the gases will escape. After all, we have assumed that gases can get in, so the enclosure is definitely not sealed.

There are several different types of “flamepath” or “gap” in a typical enclosure. The simplest to understand is the plain flange gap.

As can be seen in the picture, if the gap is wide enough, the flame will exit the enclosure and would ignite any external gas or vapour/air mixture. If the gap is narrow, and of sufficient length, the residual flame or hot gases, leaving the gap, will not ignite the external mixture. There are three contributory factors:

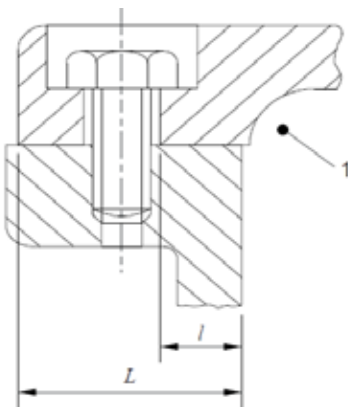
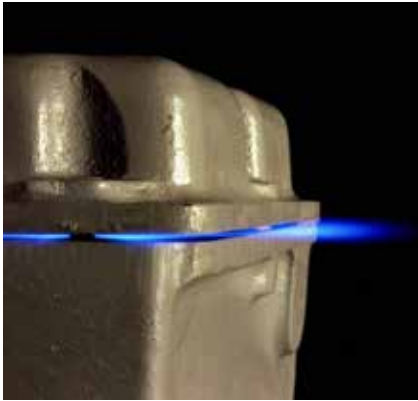

1. The pressure drop through the gap will cool the exiting gases. This is exactly according to the Universal Gas Law. We are reasonably familiar with the fact that pumping a bicycle tyre raises temperature and letting air out through the valve cools the air coming out. In some types of construction, this effect alone is sufficient, but in the case of the plain flange gap we rely on at least one other effect.

2. As can be seen in the picture, the exiting flame is in the form of a linear jet. This rapidly moving flame acts to create a low pressure zone that “sucks” the cold external atmosphere into the residual flame in a way that “snuffs it out”. This speed/pressure relationship was first described by Bernoulli and leads to the conventional design of an aircraft wing, where the top surface of the wing is longer than the under surface, so that the relative speed of the air on top is higher than the relative speed of the air below and there is an upward pressure. A similar effect is observed at the venturi in a Bunsen burner, where the rapid movement of the gas sucks the air in through the air hole.

3. Transfer of heat energy to the surfaces of the gap does occur, but it plays a very minor part compared to the other two mechanisms.

There is a trade-off between gap length and gap width, with the longer the gap length, the wider the permitted gap. The permitted gaps also vary with the enclosure volume and for particular gases, specifically in relation to their flame velocities in free air and the minimum amount of energy required to initiate an ignition process.

In order to standardize the gaps, we have four designated gas groups, and each has its own “characteristic gas” used when describing the suitability of a particular enclosure.

Experimental work has also shown the effect of interrupting the flamepath, for example by passing fastening screws between a cover and a lid, across a plain flange gap.

The groups, free field flame velocity and minimum ignition energy, are characterized as follows:

GROUP	CHARACTERISTIC GAS (USED FOR TESTING)	FLAME VELOCITY M/S	MINIMUM IGNITION ENERGY (MICRO JOULES)
I	Methane (representing firedamp in the mining situation)	3.5	525
IIA	Propane	4.0	320
IIB	Ethylene	6.5	160
IIC	Hydrogen	20	40
	Acetylene	14	40

The permitted gaps are designated in the standard and reference should be made to Tables 2 and 3 in standard IEC 60079-1.

Hydrogen and acetylene are both described as the characteristic gases for Group IIC, as it is necessary to perform some of the tests with both gases. Occasionally, if the enclosure will not pass the tests for acetylene, the equipment may be marked for “IIB + Hydrogen”.

Although it might be expected that an enclosure designed to meet the gap dimensions given in the standard should pass a transmission test (with the explosive gas mixture both inside and outside the enclosure), this is not always so. At the high pressures achieved inside the enclosure, it cannot be assumed that the designed gap will always be maintained. Even apparently rigid constructions can flex sufficiently for the gap to open under the dynamic pressure, allowing the hot gases to escape without sufficient cooling, and therefore allowing the external atmosphere to be ignited.

As part of the testing sequence, the enclosure will have already been stressed by being subjected to a static (hydraulic) pressure that can have permanently opened the gaps a fraction. In the case of plain flanged joints, this problem can often be overcome by adding further securing fasteners.

At SGS Baseefa, we can often predict which enclosures will transmit the ignition in this way, based on our experience of similar designs, and can advise manufacturers ahead of commencing a testing sequence. Of course, the manufacturer has a perfect right to insist that we test his original design, but it is usually more economical to add strength at the design stage, rather than risk the upset, in terms of both cost and time delay, of a failure at the end of the testing programme. Because we cannot undertake "design consultancy", being incompatible with our role as a third-party test laboratory, we would never prescribe exact changes to a design. A failure is still conceivable with an improved design, but the odds of success will have been greatly improved.

### GAPS WITH ANGLES

The standard describes a number of flamepaths where the escaping hot gases have to negotiate right-angled bends. Each time a fast moving gas stream encounters a sharp bend there is a resultant significant pressure drop. In most cases, this, along with the length of the path, is sufficient to ensure that the pressure drop alone will cool the gases to a low enough temperature.

The simplest gap with an angle is the spigot joint.

A spigot joint comprises a flat part and a cylindrical part.

As can be seen, both the flat part and the cylindrical part can be considered as contributing to the gap length, but the standard places limitations on the distribution of the gap between the two parts. If the distribution is not within that limitation, either the flat part, or the cylindrical part must meet the requirements of the standard alone, without any assumed contribution from the other part.

Unlike the plain flange gap, the spigot joint is inherently rigid and less susceptible to dynamic alteration during the explosion, so it is a reasonable anticipation that all such joints will behave as intended. However, testing is still necessary as unanticipated effects may occur.

Tapered spigot joints (conical joints) are permitted, with the standard laying out limits on the degree of taper. Such joints can ease the removal of parts that might be difficult with a pure cylindrical part to the spigot where tolerances are tight.

However, tighter control is needed over the machining and inspection process.

Labyrinth and serrated joints are also possible, although unusual, but each have their own additional requirements laid out in detail in the standard.

### THREADED JOINTS

All such joints are designed to be capable of preventing transmission with the tolerances set on both parts to achieve the loosest fit. The standard makes much of thread tolerances and the ability to both machine and inspect threads to the stated tolerance is a major part of the audit of a manufacturing facility. At the extreme of tolerance, the "gap" along the thread path will be greater than permitted for a flanged joint, but the length of the path is the multi-turn spiral of the thread in the hole. Thus numbers of threads engaged is also a critical feature.

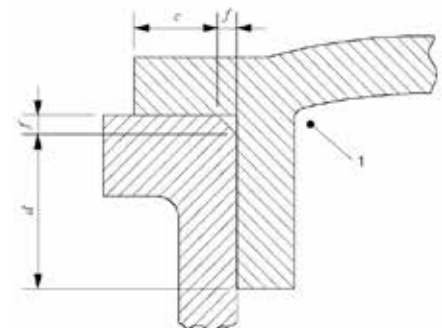

#### Key

$$L = c + d \text{ (I, IIA, IIB, IIC)}$$

$$c \geq 6.0 \text{ mm (IIC)}$$

$$\geq 3.0 \text{ mm (I, IIA, IIB)}$$

$$d \geq 0.50 L \text{ (IIC)}$$

$$f \leq 1.0 \text{ mm (I, IIA, IIB, IIC)}$$

$$1 \text{ interior of enclosure}$$

Although enclosures are sometimes made with large diameter threaded covers, this poses an additional issue. There is a requirement that all flameproof enclosures should require the use of a tool to be opened. As such covers can usually be "spun off" by hand; it is normal practice to use a hexagonal key grub screw (outside the flamepath) to act as a locking device that prevents inadvertent opening of the enclosure.

Threads that are not intended to be opened in service do not require such an additional mechanism.

### **CABLE ENTRIES**

The most prolific threaded joint is between a cable entry device and the wall of the enclosure. Threads are specified so that any gland with the correct thread can be screwed into the hole in the enclosure with a certainty that there will not be transmission along the threaded joint.

The installer is not permitted to drill and tap additional entry points, as there is no recorded evidence that any particular installer has the required capability to control the drilling and tapping, or the ability to inspect the drilling and tapping, to the requirements of the standard. (Contrast this with the ability of the installer to drill additional clearance holes in an increased safety enclosure, for the fitting of additional entry devices.)

Thus enclosures are often provided with more entry holes than is necessary, to allow for future modifications. Such holes are closed with certified "stopping plugs" that are designed with a matching thread and also cannot be easily removed from the outside of the enclosure.

Where, because of cable size, it is necessary to choose a gland with a thread size different to the hole in the enclosure, a certified "thread adaptor" can be used.

Adaptors are available to effectively increase the size of the hole, or to reduce it, as well as to change between different thread standards. It is not permitted to create a "Christmas tree" by screwing adaptors into adaptors. Only a single adaptor can be used in each entry. Multiple adaptors would lead to questions about increasing the volume of the enclosure (affecting explosion pressure and transmission potential) and mechanical strength (related to dropping the impact weight on the end of the gland).

The "flameproofness" of the cable within the gland is considered later in this document.

### **GAUGING OF THREADS**

The gauging of cylindrical threads is comparatively simple, involving just the use of "go/no go" gauges for both the male and female threads. However, the gauging of tapered threads needs a greater understanding of the process. In addition to getting the form of the thread right, the joint (usually between a gland and the enclosure) must have the correct gauging point in relation to thread penetration, in order to ensure the requisite number of threads engagement. If the female thread has not been tapped deep enough, or the male thread not tapped long enough, it could be possible, despite the threads being absolutely correct, that there would be insufficient engagement and the joint may not be flameproof.

### **THE GAP IN CYLINDRICAL JOINTS**

If the shaft element of a cylindrical joint could always be considered to be in the centre of the bore, it might be reasonable to take the radial clearance as the width of the flamepath. Unfortunately, circumstances dictate that such a situation is impossible to guarantee. Therefore all calculations are based on the assumption that the shaft is hard over against one side of the bore, and it is the diametrical clearance that is considered as the width of the flamepath. For an electric motor, the actual position of the shaft will vary dynamically, based on forces such as "unbalanced magnetic pull" and any whirling action of the weight in the middle of the shaft. Motors with oil lubricated plain bearings will alter the vertical position of the shaft within the bearing according to rotational speed and the related build-up of the oil film.

The same restrictions are placed on stationary shafts, such as for push-button operators.

## GASKETS IN FLAMEPROOF JOINTS

It is not permitted to use gaskets that would prevent the enclosure being fully secured if part of the gasket was missing. Thus flat gaskets cannot be used in flange joints. A typical gasket in a flameproof joint will be an O-ring, sized so that under compression it can be squeezed totally into its recess in one face of the joint, allowing the gap to be controlled by metal to metal contact. The transmission tests are performed with the gasket removed. Only gaskets supplied as part of the enclosure design are permitted. The location of the gasket within the flamepath is carefully controlled by tables of dimensions in the standard.

It is difficult to provide effective weatherproofing of a flameproof enclosure as an "afterthought" if gaskets were not provided as part of the design. Soft (non-setting) grease can be used in the flamepath, but care needs to be taken for chemical compatibility. For example, silicone grease may be favoured for its non-setting properties, but it cannot be used anywhere near gas detection equipment as it can poison the detector elements. The installation standard permits the use of a non-setting grease loaded fabric tape (Denso Tape) provided that only one layer of tape is used, which can be easily blown clear in the event of an explosion. This is not permitted for Equipment Group IIC. For specific details, refer to IEC 60079-14.

The installation standard also places great emphasis on the need to avoid obstructing the flow of gases from a plain flange joint. To do so would interfere with the necessary entrainment and destroy the effectiveness of the design. Horror stories emerge of installers and users of equipment who have ignored this and fitted rain shields very close to the gaps, thus rendering the protection concept ineffective.

When a flameproof enclosure is painted, great care must be taken to ensure that no paint can enter the gap. Paint, as with a setting grease, will break away as the enclosure is opened and some of the residual material will probably prevent the lid seating correctly again, when an attempt is made to replace it, thus ensuring that the gap after reassembly is, unfortunately, greater than before opening. Additionally, there would be concern that using tools in a way that would "break" a setting grease or painted joint might damage the flamepath.

## FASTENERS

A fastener is any device intended to hold an enclosure together and includes bolts and studs, as well as nuts and threaded holes. If a fastener fails, the enclosure is not flameproof. The two most common failure modes of an enclosure under pressure are for the fasteners to stretch beyond their yield point and break, or for the threads to strip. In many cases, it is necessary to specify high-tensile fasteners. See IEC 60079-1 Annex F. If an enclosure is tested with the high-tensile fastener, and passes the pressure test, the enclosure may not remain flameproof if a mild steel fastener is substituted.

Many years of experience in testing enclosures allows a build-up of confidence such that a good guess can be made as to whether or not a particular fastener is suitable. In the photograph, the pressure on the end shield of the motor had been sufficient to stretch all four fasteners beyond their breaking point, resulting in the end shield separating from the main barrel of the motor. To the practised eye, the construction looked weak, but the manufacturer insisted it would be OK. A redesign with larger diameter fasteners resolved the problem.

The original fasteners would have been perfectly sized for the industrial duty, holding the spigotted end shield in place against vibration and rotational forces, but not fit for flameproof purposes.

All fasteners must be fully specified. This includes material grade, thread form and length. The length becomes particularly important if the fastener is to be inserted into a blind threaded hole. The thread engagement cannot be assessed after assembly, so a short bolt may not engage sufficient threads, resulting in thread stripping. A long bolt may "bottom" in the hole, resulting in either insufficient pressure on the parts being held together, or in the possibility that over-tightening the bolt may split the threaded part of the enclosure. The standard requires a design clearance of at least one full thread remaining free with all washers removed together with a minimum wall thickness around the thread of 3mm at the bottom of the hole.





Where a fastener penetrates a flamepath, the standard gives great detail on where, within the flamepath, the fastener may be used. Care is needed to ensure that the appropriate construction is chosen from the various different drawings, to select the correct set of values.

### THE DEVELOPMENT OF EXPLOSION PRESSURE AND PRESSURE PILING

As indicated earlier, simple enclosures give rise to reasonably well-predicted explosion pressures, but real enclosures, with real contents, create additional problems.

This is down to the way that the explosion develops within the available space. The more "free" space, the lower the likely explosion pressure. The recommendation to avoid undue pressure build-up is to ensure that at least 80% of every cross-sectional area, in every plane, within the enclosure is free to allow development of the explosion. If the explosion is constrained by compartmentalization of the enclosure, unburnt gases can be forced ahead of the flame into other spaces from which the subsequent burnt gases cannot so easily escape.

Consider a simple enclosure of two compartments as described in the figure. If the ignition point is at A (at the pathway between the two compartments), there will be no increase in pressure because of compartmentalization. However, with the ignition point well away from the pathway, at B, the developing pressure from the initial explosion will push unburnt gas into the second compartment, possibly raising the pressure from 1 bar to 1.5 bar. The flame then follows and the ignition is of "pre-compressed" gas. If the explosion pressure in the first compartment was 6 bar, the explosion pressure in the second compartment will be 9 bar. It is a simple multiplication. Consider further compartments similarly separated. Perhaps the 9 bar explosion results in pushing sufficient unburnt gas into a third compartment to achieve a pressure of 3 bar before the flame arrives and ignites it. The pressure of the explosion in the third compartment will then be 18 bar.

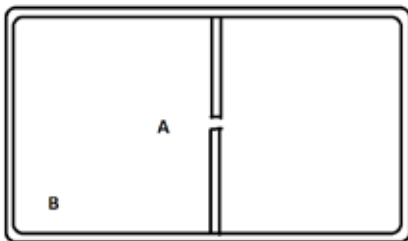

The figures are just given for illustration, but although such strict compartmentalization is unusual, partial compartmentalization is easily achieved in the real world, just by over-filling the enclosure with hardware and wiring. This also illustrates why the standard requires that pressure is determined using an ignition source placed at possibly several representative ignition points within the enclosure. Careful attention to layout of the contents and of the wiring within the enclosure can minimize the effects of this "pressure piling".

For larger enclosures, particularly involving tubular constructions, a second effect can also occur, where the propagation of the explosion within the enclosure is no longer by flame transfer but by pressure wave ignition. This leads to detonation, where effectively the remaining gas is ignited simultaneously, and very high pressures can develop. This is a particular problem with large electric motors with ventilation holes in the stator or rotor core packs. It can also affect the design of fluorescent lamp fittings if they require suitability for Group IIC.

From our years of experience, we can provide basic advice on minimizing the effects of pressure piling and detonation in particular situations.

### COMPONENT CERTIFICATION

As an extension of a process that we developed over forty years ago in the UK (and PTB developed in Germany), current standards recognize that it is often appropriate to issue certification documentation for items that are not completely flameproof equipment in their own right, but contribute to the flameproofness of the equipment that they are built into. It is easy to see how a push-button actuator, designed to be mounted through the wall of an enclosure, can be certified as a component, such that when the equipment is certified there is no need to further consider cylindrical flamepaths on the shaft, physical robustness, etc.

In the same way, an empty flameproof enclosure can be tested for strength at given pressures and for non-transmission. The standard goes into great detail on this process, including providing a statement on the limitations to be imposed on what might be put in the enclosure. It is made absolutely clear that the Component Certified enclosure is not suitable for immediate installation in the hazardous area, but first must be submitted, with the intended content, to a certification body, to allow an equipment certificate to be issued. If the statement of limitations is fully

observed, it is often possible to issue certification without further testing. If there are minor breaches of these requirements, further testing can take place, but with the assurance that the enclosure is already fully defined, and the extra work is minimized.

Unfortunately, some installers have misunderstood the intent of the Component Certificate system and have installed the enclosure and filled it with contents themselves. To try and minimize the probability of this happening in the future, the standard now requires that empty enclosures should have their Component Certification label on the inside, and not visible in the final installation.

### **SPECIFICATION OF CONTENTS**

Because it is assumed that something in the enclosure may act as an ignition source, it is not necessary to specify the last detail of every item that might be mounted in the enclosure. However, it is critical that the physical outlines of the items are fully defined and that the power dissipation from each item is known. Thus explosion pressures and external surface temperatures are under control.

There is an art in specifying the contents, in order to provide the manufacturer with maximum flexibility, but allow the certification body confidence that the necessary information is present.

For certain types of equipment, we would expect to see drawings giving the exact dimensions and positions of everything within the enclosure. However, for more general types of equipment, such as control stations and switchgear, where the minimum free area in every cross-section is easily above the 20% minimum desired value, it is often possible to apply a much looser specification, provided that the maximum content of the enclosure is absolutely defined. Thus the drawing might, for example, show the location of ten contactor blocks within the enclosure, but the certificate could allow "up to" ten contactor blocks. Thus the manufacturer would have the option of supplying the enclosure with less than the maximum number shown on the drawing. In this case, we can be happy that we have captured both the maximum pressures and the maximum external temperature rise.

We will always provide this flexibility to manufacturers when we can. It gives an element of future proofing, so that the same certificate can be used for future production, even with variations from the original design.

Note that when we need to perform explosion tests with items fitted in the enclosure, the items can sometimes be represented by wooden block dummies. This can avoid potential damage to expensive items, but still give a realistic result for the explosion pressure. We keep a stock of dummy light bulbs that can be fitted to luminaires, rather than risk destroying a lamp with every ignition sequence. We will discuss the options with you when you submit an initial application for test and certification.

For the purposes of measuring temperature rise (where an engineering judgement is not sufficient) it is possible to use resistive dissipative loads within the enclosure, rather than the actual contents, provided that the heat dissipation is not directly through the wall of the enclosure by the way an item is mounted. Engineering judgement can be used to wave a temperature test when it is clear that the total power loss in the enclosure will not allow the wall temperature to approach the Temperature Class limitation. For example, 5W dissipation within an enclosure that is 300mm cubed and for installation in an ambient no higher than 40°C, can automatically be awarded T6 without test. If the dissipation was 200W, a test would usually be required, although T3 could be awarded without test.

### **PENETRATIONS THROUGH THE ENCLOSURE WALL**

Any penetration through an enclosure wall (or through the lid or base of an enclosure) must meet flameproof requirements. Holes for push-button operators or switch spindles can be matched with Component Certified items, or the items can be considered as part of certification of the equipment. Holes for cable entries can be threaded to receive certified glands or conduit fittings. Those glands or fittings are not normally specified as part of the equipment, but are left open for the installer to provide an appropriate gland or fitting, once the cable or conduit is specified for the actual installation. Where the installer chooses not to fit a gland or conduit fitting, the hole must be closed with an appropriate certified stopping plug, as described earlier.



Each penetration reduces the strength of the enclosure, so it is important that tests are performed on the weakest version of the enclosure. To allow flexibility, the manufacturer will often supply more entry holes than are actually required. In the case of an enclosure that is to be the subject of Component Certification, the final number of entry holes in each piece of final equipment is not known. The tests are therefore performed on an enclosure that has been drilled and tapped to accept the maximum number of entries that can physically be accommodated, with each hole provided with a stopping plug. On this basis, the test covers any enclosure with the maximum number or less of entries.

The manufacturer has the option of providing the maximum number of holes, or a lesser number if that is appropriate for the application.

### ENCLOSURE MATERIALS

The enclosure used for testing should be of the same material that will be used for production. This seems an obvious statement, but it is not always appreciated that different grades of the same material, never mind different materials, will usually provide different strengths to the enclosure.

Some equipment will always be made with just one material. Other equipment may be offered for sale in a choice of enclosure material to suit different environments. Aluminium alloys are fine for some applications, but useless in others, such as on the deck of a rig in the North Sea.

If different materials are contemplated, we recommend an early discussion, so that we can ensure that the weakest material has been chosen for testing and all potential materials can be included in the certificate.

### REQUIREMENTS FOR ABNORMAL AMBIENT TEMPERATURES

For equipment tested at normal laboratory ambient temperature, the tests are considered valid for equipment used within the range -20°C to +60°C. This is the unofficial scope limit of the ATEX Directive and is replicated in the standards.

However, equipment can be subjected to additional tests and certified for ambient temperatures outside this range.

Simplest to understand is the tendency to increase the likelihood of transmission at higher ambient temperatures. The external gas is already heated, so will not provide all of the expected cooling from the Bernoulli Principle. Additionally, the pressure drop through the gap will be less, as the temperature difference will be less. The standard makes provision for gaps to be widened to allow a normal ambient test to simulate the effect of the higher ambient.

At the other end of the scale, cold ambient temperatures result in higher explosion pressures. Once again we rely on the Universal Gas Law:

$$\frac{P \times V}{T} = \text{Constant}$$

If the enclosure was sealed, the reduction in temperature would cause a reduction in pressure – but the enclosure is not sealed and the effect is that the enclosure now contains a greater quantity of actual gas molecules, in order to bring the pressure back up to ambient. The lower the temperature, the greater the number of gas molecules in the enclosure, i.e. the greater the density of the explosive mixture.

When the ignition occurs, we are igniting a larger quantity of both gas and air molecules, compared with the situation at normal laboratory ambient. Thus, using the gas law, the final pressure will be higher than when igniting the mixture at normal ambient. At higher temperatures, the density will be less, so the explosion pressure will be less (and not a problem).

The standard provides a formula to calculate the increase in pressure based on ambient temperature, but this can only be reliably applied to smaller simple enclosures. As the gas density increases, so the propensity to move into a pressure piling situation increases. The flame speed in the cold gas is less than in the normal ambient, providing a greater opportunity for the unburnt mixture to be forced ahead of the flame front. This slower development cannot be reliably predicted, and, as soon as we are dealing with a more complex enclosure, pressure piling can suddenly start at an unpredictable ambient temperature. Thus going down from say -30°C to -40°C could lead to a doubling in pressures.

At Buxton, we have always had the capability of testing medium size equipment at ambient temperatures down to -55°C, but, with the development of oil exploration in the Arctic, we are often being asked for the testing of larger equipment at even lower temperatures. We have commissioned a test rig that will allow explosion testing of large equipment (up to a 630 frame motor) at temperatures as low as -65°C, which may be unique in the world.

### CABLE ENTRY SYSTEMS

Cable Glands and related items are very closely specified in the standards. Annex A to IEC 60079-0 is seven pages and Annex E to IEC 60079-1 is nine pages. Both sets of requirements must be met for flameproof entry devices.

For flameproof, the critical feature not applicable to the other protection concepts is the ability to prevent the transmission of an explosion either directly around the cable sheath or through the interstices that are typically present in most cables. Even a cable with the external sheath moulded around the cores may still have a hole down the centre of the cable where the moulding material has not penetrated.

Armour or braid is normally separately terminated in the gland, external to the flameproof aspects, to avoid the possibility of transmission along the armour or braid.

The largest problem is that cables are not subject to certification, so it is not possible to specify that a cable is certified for use with particular entry devices. However, the latest edition of IEC 60079-14 provides a test, in Annex E, to enable an installer to judge whether or not the cable he is using can be classed as "fully filled". The test is rather loosely specified, but we are finding that installers on large sites are asking us to perform the test and supply a test report.

For all cables that are not fully filled, the entry device must include provision to prevent the explosion being transmitted. This can be either a "rubber bung" with individual holes for each cable core, or a gland designed to be filled with compound during installation. Similar arrangements can be used as conduit sealing.

The manufacture of entry devices is a specialized activity, so no further information is provided in this Technical Bulletin.

### PREPARING SAMPLES FOR TESTING

We appreciate that there can be an eagerness to supply us with samples for testing, but unless the details of the standard are fully understood, we may not be able to use samples that the manufacturer sends ahead of discussions with us.

In the previous sections, we have attempted to indicate the "why" as much as the "what" of the requirements. Hopefully this will have given an understanding that test samples must often be specially prepared. Consider particularly the enclosure material and the number of entries, as well as attention to the actual flamepaths.

We need to be able to test an equipment with flamepaths opened to at least 90% of the maximum permitted by the standard. For plain flange gaps, we can arrange this with shims, but all other forms of flamepath require special manufacturing to ensure that the gaps are correct for test purposes. We are permitted to test with tighter gaps, but this automatically results in an "X" condition on the certificate and special provision of documentation related to maintenance and repair. It might also be difficult for the manufacturer to hold to those tighter tolerances in his manufacturing process. Our strong recommendation is always to provide samples near the permitted maximum tolerances. We will discuss this with you when we request samples.

As part of the test procedure we require inlet and outlet ports for the test gas flow, and at least one (possibly more) penetrations to allow the mounting of the spark ignition device that will initiate the explosion. Explosion pressure is measured with piezo transducers mounted through the body of the enclosure and set flush to the inside surface. Although we do not usually use all pressure measuring channels, we can measure pressure at eight points simultaneously. Most equipment is tested with three to six transducers. We can sometimes use existing penetrations (such as spare cable entries) but these are not always in the most advantageous positions, so drilling and tapping additional entry holes is usually required. We can do this at Buxton, but it will usually be more economical for the manufacturer to supply the sample with these additional entry points already in position. We will select and advise the most appropriate positions.



For some types of equipment we may require more than one sample, or additional part samples. This often relates to the thermal conditioning of non-metallic materials. Plastic is permitted to be used as the construction material for flameproof enclosures, but practicality indicates this is only applicable at the lowest end of the size range. There is also an extended "flame erosion" test, to demonstrate that the plastic material will not deteriorate in the flamepath when it is subject to multiple explosions. Windows are usually of armoured glass (although some special plastics may be acceptable) and they are mounted in a separate "window frame" before mounting to the enclosure. The glass is held in the frame with cement that is subject to various additional tests. For pressure determination tests, it is preferable to replace the window with a metallic duplicate of the glass, assembled in the same way as the glass and drilled and tapped with a hole suitable for fitting a pressure transducer.

### **CERTIFICATION IS NOT JUST TESTING**

A certificate does more than confirm that a product has passed a number of relevant tests.

Through the drawings (which are part of the certification package) those aspects of the equipment that contributed to the passing of the tests is tied down, sometimes in great detail. There are other requirements in the standards (such as related to marking) which do not involve any aspect of testing, but must be confirmed in the documentation.

Many years ago, we created a guide to the preparation of documentation to accompany an application for certification. Over the years, this guide has been exposed to international comment and is now published as IECEx Operational Document OD 017. Copies can be downloaded from [www.iecex.com](http://www.iecex.com) and should prove useful to those that are not familiar with the requirements.

Certification is also about ensuring that subsequent production is directly equivalent to the "type" that was tested.

In the IECEx international certification scheme, the certificate is only issued when both the "type examination" part of the process and the "QA surveillance" part of the process are in place. There is no point in ensuring the sample passed all the tests if the subsequent production is inferior.

The legal system in Europe, the ATEX Directive 2014/34/EU, does not put the two aspects together in quite the same way. It is the manufacturer who is responsible for issuing his Declaration of Conformity (DoC) based on the existence of both an EU-Type Examination Certificate and a related Quality Assurance Notification (QAN).

The ATEX Directive has a number of different conformity assurance modules, but it is expected that, for flameproof equipment, the modules related to Type Examination and QAN will have been completed.

More information is available on our website [www.sgs.co.uk/sgsbaseefa](http://www.sgs.co.uk/sgsbaseefa). If you have any questions related to the testing and certification of flameproof equipment, or if you would like to discuss your project with a certification engineer, please contact Mark Wilson who manages flameproof certification for SGS Baseefa:

#### **MARK WILSON**

Certification Manager  
Phone: +44 (0) 1298 766622  
Email: [Mark.Wilson@sgs.com](mailto:Mark.Wilson@sgs.com)

#### **GENERAL ENQUIRIES**

Phone: +44 (0) 1298 766600  
Email: [baseefa@sgs.com](mailto:baseefa@sgs.com)

**WWW.SGS.COM**  
**WWW.SGS.CO.UK**

**WHEN YOU NEED TO BE SURE**

